

EXPRESS 220 IF-2

Bread & Roll Moulder

Artisan - Retail - Wholesale Bakeries
Supermarket In-store - Food Services

FOR MOULDING:

- ▶ White & wholewheat breads
- ▶ Artisan breads & rolls
- ▶ Rye & pan breads
- ▶ Subs, hoagie & hotdog rolls
- ▶ Finger rolls, challah & pretzels
- ▶ Tapered rolls & bolillos*

* with optional curved pressure plates

OUTSTANDING FEATURES:

- ✓ Variable speed infeed belt with guides
- ✓ Adjustable loading height from 24" to 40"
- ✓ Hand feed or use with a "Single or Dual knife divider"
- ✓ Produce up to 7,200 pcs./hr. Capacity from 1/2 oz. to 4 lbs.

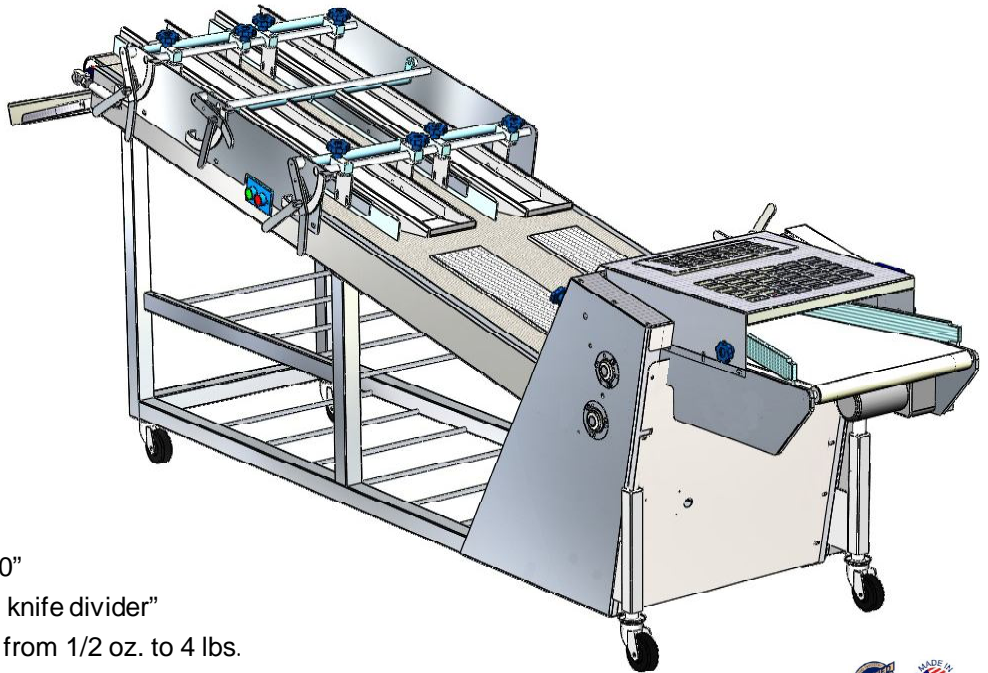

SPECIFICATIONS

ROLLERS:	4" Diameter synthetic rollers and scrapers
MOTOR:	1½ HP, TEFC motor, 1 PH/115/230V/60Hz
BELT:	FDA approved polyester, 24" wide
SAFETY SYSTEM:	Infeed guard bar with automatic shut off
PRESSURE PLATES:	2 per machine (specify size), Duals up to 9" wide
SHIPPING WEIGHT:	Approximately 1,200 lbs.
MACHINE DIMENSIONS:	117" L x 30" W x 47" H

OPTIONS

PRESSURE PLATES:	Single or dual plates 3", 4", 5", 6", 8", 9", 10", 12", 14", 16", 18", 20" & 22" flat x 56" long 6" or 7½" curved x 22" long Custom plates available
MOTOR:	6 Options available
FLOUR DUSTER:	Consult factory

The **EXPRESS 220 IF-2** design uses two extra long pressure plates to give the dough more time to form the correct length. Moulds 2 pieces at the same time, up to 9" long. Converts to single row production for breads and baguettes up to 22" long. This moulder can be coupled directly to a gentle divider to eliminate the intermediate proofer.

Moulds up to 4,000 lbs/hr when used with a divider.

BLOEMHOF INC. offers you dough friendly moulders with the patented spring loaded roller system and fully adjustable side guides.

GENTLE • LABOUR SAVING • FAST

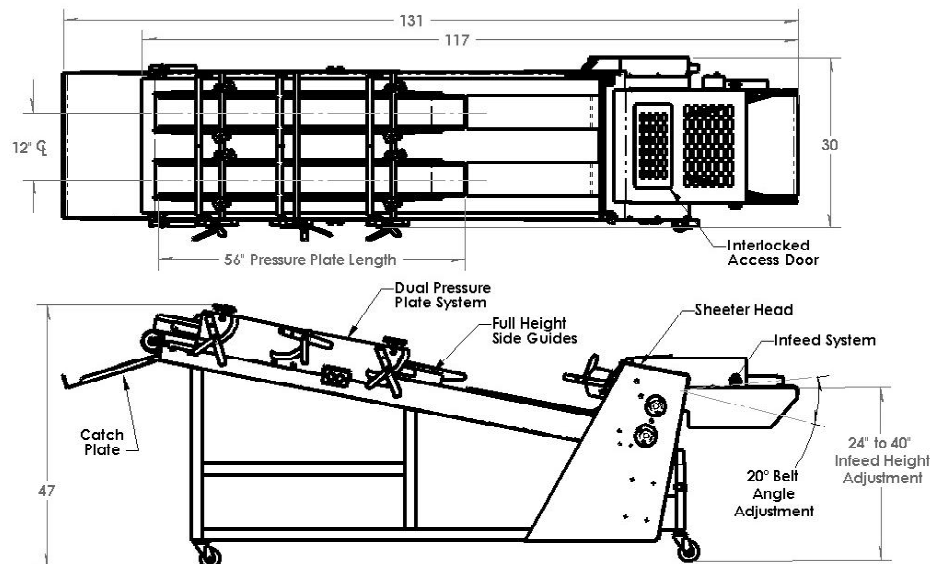

Quality Bakery Equipment Since 1960
12503 - 62nd Street,
Edmonton, AB. Canada T5W 4W9
Tel. (780) 476-2131 Fax (780) 476-7813
www.bloemhof.com

Specifications subject to change without notice

EXP 220 IF-2 Sept 5 2007
PRINTED IN CANADA